

## LN08-LN09 CEILING LIGHT



### \* Product features:

- High-quality LEDs provided by Samsung/ Seoul Semiconductor/ Nichia/ Lumiled with excellent performance
- Die-casting aluminum and metal housing with perfect heat dissipation
- Optical grade and anti-yellowing PMMA light guide plate and PS cover with high lighting transmittance and desired lighting distribution
- Flicker-free
- CE, KC certified
- Long lifespan: 20,000 hours, saving the maintenance cost

### \* Applications:

- Suitable for Home, office, restaurant, hotel, supermarket, commercial centers, showrooms, etc.



## PRODUCT DETAILS

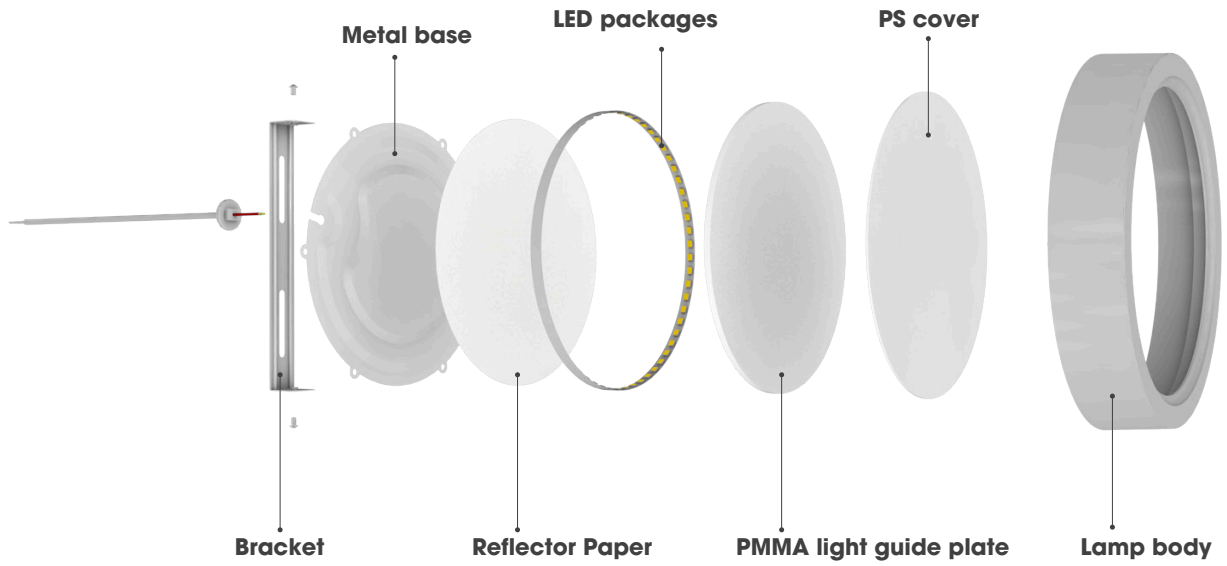

## PRODUCT SPECIFICATIONS

LN08

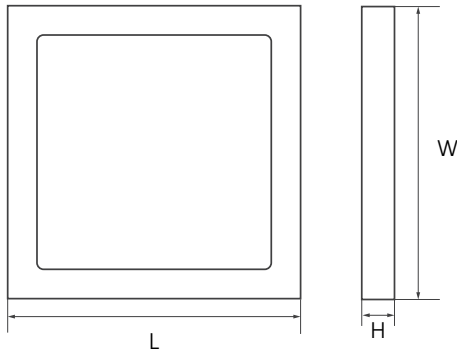

LN09

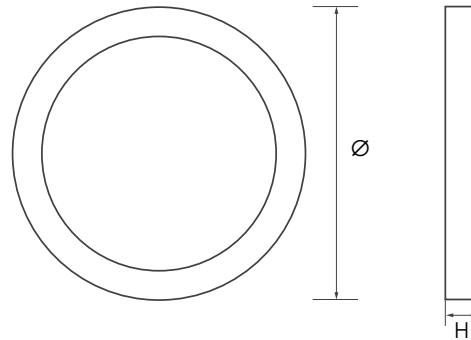

Model	Dimension ΦxH/ LxWxH (mm)	Power (W)	Voltage (V)	Power factor	Luminous flux (lm)	Luminous Efficacy (lm/W)	CCT (K)	CRI (Ra)	Life span (hrs)
LN08 170x170/15W	158x158x29	15	120/220÷240/100÷277	0.5/0.9	1425	95	3000/4000/5000/5700/6500	80	20,000
LN08 220x220/22W	208x208x29	22	120/220÷240/100÷277	0.5/0.9	2090	95	3000/4000/5000/5700/6500	80	20,000
LN08 300x300/30W	280x280x29	30	120/220÷240/100÷277	0.5/0.9	2850	95	3000/4000/5000/5700/6500	80	20,000
LN09 170/15W	158x29	15	120/220÷240/100÷277	0.5/0.9	1425	95	3000/4000/5000/5700/6500	80	20,000
LN09 220/22W	208x29	22	120/220÷240/100÷277	0.5/0.9	2090	95	3000/4000/5000/5700/6500	80	20,000
LN09 300/30W	282x29	30	120/220÷240/100÷277	0.5/0.9	2850	95	3000/4000/5000/5700/6500	80	20,000

**Capacity: 11.2 million pieces per year**

**Customizable:** Power (15W/22W/30W), Voltage (120/220÷240/100÷277), PF (05/09), lm/W, CCT (3000/4000/5000,5700,6500K), CRI (80/90/Sunlike), Driver (non isolated), lifespan, etc.

## LUMINOUS INTENSITY DISTRIBUTION

LN08/09 15W

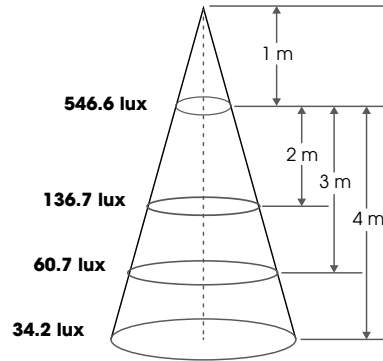
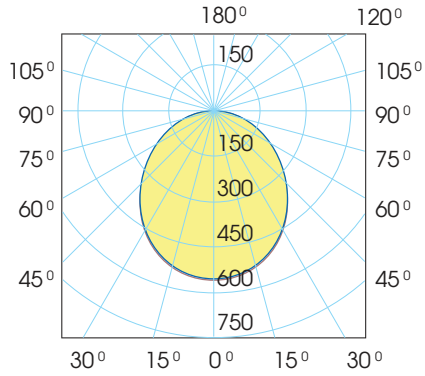

LN08/09 22W

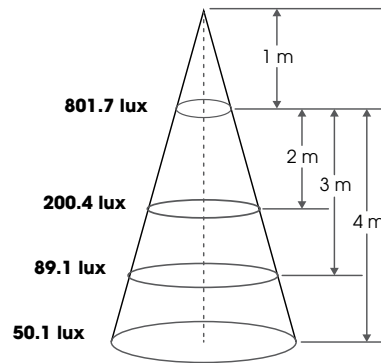
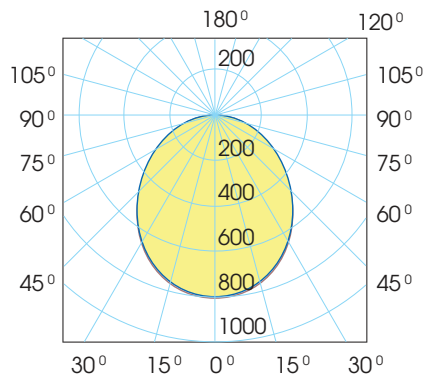

LN08/09 30W

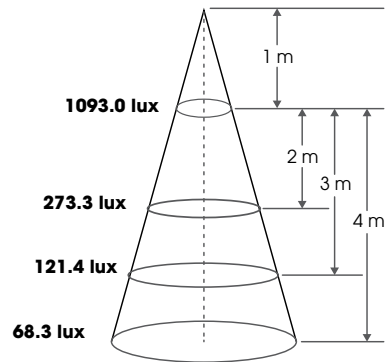
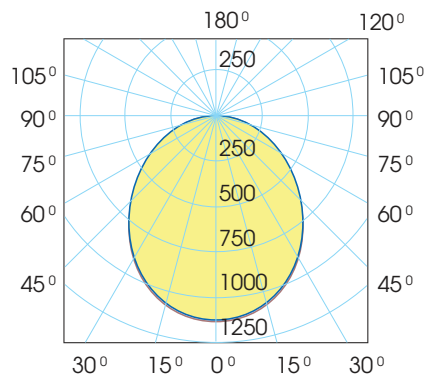

## PACKING AND TRANSPORTATION



Customizable according to customer's request

Type of lamps	Quantity in master box (pcs)	Estimated quantity/ 20'DC	Estimated quantity/ 40'HC
LN08/09 15W	8	31,088	71,392
LN08/09 22W	8	19,024	43,680
LN08/09 30W	6	9,504	21,822

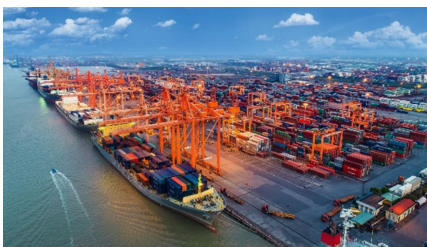

Exported markets: EU, South Korea, etc.



### RANG DONG LIGHT SOURCE AND VACUUM FLASK JOINT STOCK COMPANY

Add: 87- 89 Ha Dinh Street, Thanh Xuan, Hanoi, Vietnam

Tel: (84-24) 3 858 4310 / 3 858 4165

Fax: (84-24) 3 858 5038

Email: [export@rangdong.com.vn](mailto:export@rangdong.com.vn)



Specifications are subject to change without prior notice